

# M50-B

## 5inch Micro Differential Pressure Meter

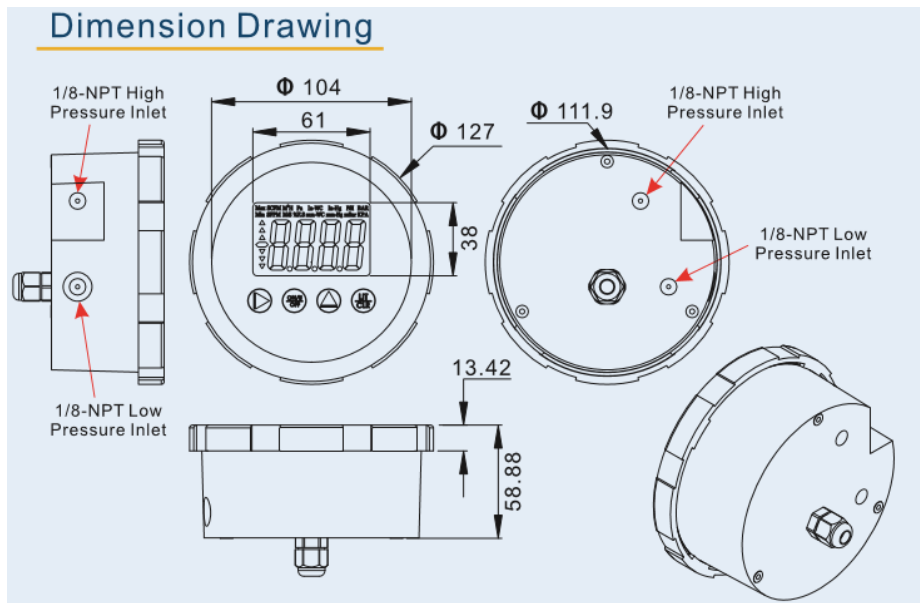

### Specifications:

Pressure range	0~±100 In-w.c./ 0~±25 In-w.c./ 0~±10 In-w.c/ 0~±1 In-w.c
Power Voltage	Battery: 3.6V lithium battery ER18505 (3500 mAh)
Display Update	Selectable for 1 to 5 seconds
Battery Life	2 years if Display Update = 1 second & no backlight
Accuracy	±1% F.S (@25±3°C)/ ±2% F.S under 1"wc
Measure fluid	Gas and non-combustible, compatible gases.
Units	In-w.c. , psi , kPa , Pa , mm-w.c. , mBar , In- Hg , mm- Hg , FS(0~100%)
Current Consumption	1mA maximum (No Backlight)
Working temperature	-10 ~ +60°C
Compensated Temperature Limits	32~122°F (0~50°C)
Size	5"(127 mm) O.D. front face
Water proof	IP65

Long Term Stability	±1% F.S. per year
Thermal Effect	±0.05% F.S/ °F typ. ; ±0.10% F.S/ °F for ranges 1In-w.c. and below.
Display	4-digit LCD with yellow-green backlight
Auto Off Time	1~10 minutes or no auto-off function
Process conjunction	1/8 NPT hole of thread
Standard fitting	1/8 hose barb